

SILICONSOFTWARE

A-Series Camera Link

microEnable IV AD1-mPoCL

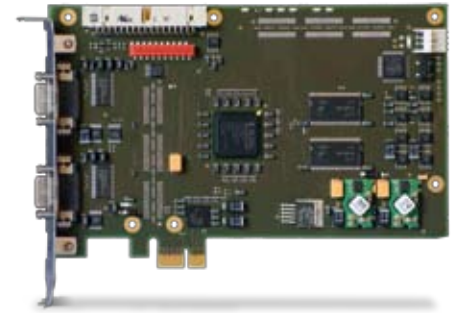

Dual channel PCIe frame grabber for Camera Link with PoCL support

The microEnable IV AD1-mPoCL is a dual-port frame grabbers for two independent Base configuration or one Medium configuration Camera Link camera. Optimized for acquiring functions, the products offer a robust and reliable acquisition technology und high performance at the same time. The functional range of the frame grabbers additionally covers valuable image pre-processings that are carried out in real time and without loading the host CPU. The trigger system of the microEnable IV AD1-mPoCL is especially high performance and offers a high flexibility and adaptability for line-scan applications. With support of the Power over Camera Link technology, compatible cameras can be powered via the frame grabber – what makes one-cable-solutions possible.

microEnable IV AD1-mPoCL is delivered with a powerful but intuitively to handle sSoftware development kit (SDK) and a wide range of drivers for 32bit and 64bit operation systems. A similar code base for software, drivers and even hardware applets and more over an common interface concept for hardware extensions and features guarantees highest compatibility between all frame grabber series.

microEnable AD1-mPoCL is the ideal entry level for image acquisition systems with moderate requirements of data bandwidth. The concept of the product series owns a high flexibility and scalability.

Product Features	
✓	Acquisition Buffer
	▶ 128 MB DDR-RAM
✓	FPGA System Processor
	FPGA Vision Processor
	Xilinx Spartan 2
	Xilinx Spartan 3
✓	Sustainable Transfer Rate (max.)
	▶ 200 MBytes/sec.

Camera Interface	
✓	Camera Link
✓	Power over Camera Link
	GigE Vision

Camera Link Standards	
✓	BASE Configuration
✓	Dual BASE Configuration
✓	MEDIUM Configuration
	FULL Configuration
	10taps FULL Configuration

Camera Interface	
✓	Camera Link Connectors
	MDR26
2	SDR26
	GigabitEthernet Connectors
	RJ45

Connectivity Features	
✓	GPIO/Trigger Connector
	PixelPlant Connector
	CLIO Connector

PC Interface	
	PCI 32/64bit
✓	PCI Express
	▶ PCIe x1 (single lane)
	▶ PCIe x4 (quad lanes)

Acquisition Features	
✓	Camera Pixel Clock Support
	▶ 85 MHz
✓	Area Scan Cameras
	▶ 16k * 64k max. image size
✓	Line Scan Cameras
	▶ 16k max. image width
✓	Grayscale Cameras
	▶ 8bit resolution
	▶ 16bit resolution
✓	Color Cameras
	▶ 24bit resolution (RGB)
	▶ 48bit resolution (RGB)
	▶ 24bit resolution (Bayer CFA)
	▶ 36bit resolution (Bayer CFA)
	Mixed Mode (requires VisualApplets)
	▶ Area Scan + Line Scan Cameras
	▶ Grayscale + Color Cameras
	▶ Arbitrary Combinations

AddOn Products	
✓	GPIO/Trigger Boards
✓	GPIO/Trigger Boards, opto-isolated
	CLIO (Camera Link Replicator)
	PixelPlant (Processing Extension)

Physical Board Properties	
	▶ 168 mm length x 111 mm height
	▶ Operating temperature 0°C - 50°C

Any information without obligation. Technical specifications and scope of delivery are liability-free and valid until revocation. Mistakes are excepted.



Image Acquisition Features

- Sensor Tap Sorting
 - Knee Lookup Table
 - Basic Image Processing, e. g. Brightness, Contrast and Gamma Correction
 - Internal 16bit Processing
 - Regions of Interest (ROI)
 - Minimal Latency of a Single Line
 - Hardware Generated Image Number
 - Camera Detection Abilities
 - No Need of Camera Configuration Files
 - Support of Camera Link RS232 Interface clser
 - Highly Customizable Trigger System
 - DigI/O and CC Signals
- ... and further ones

Special Features

- Shaft Encoder A/B Support (Revolving Direction Detection and Compensation)
 - Software Trigger Control
 - Support for Non-Standard Formats
- ... and further ones

Software Products

- ✓ Device Drivers
- ✓ Firmware Flasher
- ✓ microDisplay
- ✓ microDiagnostics
- GigE Explorer
- ✓ microEnable SDK

Processing Libraries

incl.	AcquisitionApplets
	SmartApplets Base
	SmartApplets Extended
	VisualApplets Base
	VisualApplets Blob
	VisualApplets Compression

Processing Licenses (Base version)

- SmartApplets enabled
- VisualApplets enabled

Operation Systems

✓ Windows XP	32bit	64bit
✓ Windows Vista	32bit	64bit
✓ Windows 7	32bit	64bit
✓ Linux (Kernel 2.6.23+)	32bit	64bit

Hardware/Software Compatibility

- ✓ microEnable IV BASE x1 mini PoCL (is discontinued)

Power-Over-Camera Link

The microEnable IV AS1-PoCL frame grabber supports Power over Camera Link (PoCL) cameras. The implementation is backward compatible to the standard Camera Link, so both PoCL and standard Camera Link cameras can be used.

To prevent any damage from the camera and grabber, a PoCL SafePower system is implemented. It automatically detects the presence of a PoCL cable and camera to allow safe switching of the camera power. Both parts of the grabber are autonomous and will be tested and supplied independently. The state of the power system will be visually indicated.

Schematic layout of microEnable IV AD1-mPoCL

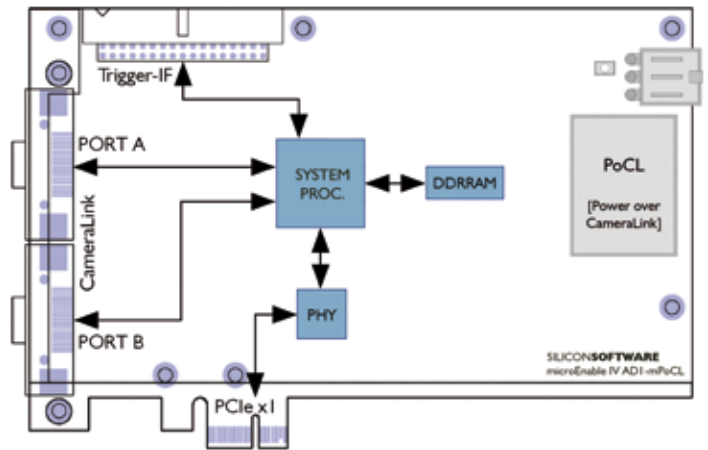

Supported Features Sorted by Hardware Applets for

microEnable IV AD1-mPoCL

	Dual Area Gray 16	Dual Area RGB 48	Dual Line Gray 16	Dual Line RGB 48	MEDIUM Area Gray 16	MEDIUM Area RGB 36	MEDIUM Line Gray 16	MEDIUM Line RGB 36
CameraLink	BASE Configuration	■	■	■	■			
	MEDIUM Configuration					■	■	■
Camera Type	Area Scan / Line Scan	A	A	L	L	A	A	L
	GrayScale / RGB / Bayer	G	RGB	G	RGB	G	RGB	G
Color Processing	1- / 2-Camera Operation	2	2	2	2	1	1	1
	White Balancing		■		■		■	
Image Enhancement	Knee-LUT Table	■	■	■	■	■	■	■
	Image Processing	■	■	■	■	■	■	■
Image Correction	Sensor Correction			■		■		■
	Acquisition Modes	■	■	■	■	■	■	■
Performances	Image Selector	■	■	■	■	■	■	■
	Area Trigger	■	■			■	■	
	Line Trigger			■	■			■
	Shaft Encoding			■	■			■
Image Formats	Max. width (in k pixels)	16	8	16	8	32	8	32
	Max. height (in k lines)	64	64	64	64	64	64	64
	Image frequency (in k fps)	20	20	10	10	10	10	10
Image Formats	Gray8 or RGB24	■	■	■	■	■	■	■
	Gray16 or RGB 48	■	■	■	■	■	■	■

Any information without obligation. Technical specifications and scope of delivery are liability-free and valid until revocation. Mistakes are excepted.

