

SILICONSOFTWARE

V-Series GigabitEthernet

microEnable IV VQ4-GE

Programmable quad port PCIe frame grabber for GigE Vision



The microEnable IV VQ4-GE is a quad-port frame grabber for four independent GigE vision cameras.

All integrated image acquisition and image pre-processing functions of the microEnable IV VQ4-GE are executed on the system FPGA in real time, and offer high performance and robust and reliable acquisition technology at the same time.



Additionally you can use SmartApplets for loading application-related image processing operations. The processing takes place with high algorithmic quality and relieves the software-related image processing.

For implementing customized image processing the vision FPGA is able to be programmed with the graphical tool VisualApplets. The microEnable IV VQ4-GE is pre-licensed for VisualApplets (Base) and SmartApplets (Base).

With its wide range of functions and its high performance, the microEnable IV VQ4-GE enables the professional use of GigabitEthernet in the Machine Vision industry.

With the help of image reconstruction the system load is dramatically decreased. Digital interfaces for signal input and output allow for a control of external devices with low latencies, and a Software Development Kit (SDK) tailored for Machine Vision enables the comfortable integration of application of your own.

Product Features	
✓	Acquisition Buffer
▶	512 MB DDR-RAM
✓	FPGA System Processor
✓	FPGA Vision Processor
	Xilinx Spartan 2
▶	Xilinx Spartan 3
✓	Sustainable Transfer Rate (max.)
▶	760 MBytes/sec.

Camera Interface	
	Camera Link 
	Power over Camera Link 
✓	GigE Vision 

GigabitEthernet Standards	
✓	GigE Vision
✓	Gen<i>Cam
	Power over Ethernet (PoE)
✓	Link Aggregation (in preparation)

Camera Interface	
	Camera Link Connectors
	MDR26
	SDR26
✓	GigabitEthernet Connectors
4	RJ45
	RJ45 with PoE Support

PC Interface	
	PCI 32/64bit 
✓	PCI Express 
	PCIe x1 (single lane)
▶	PCIe x4 (quad lanes)

Connectivity Features	
✓	GPIO/Trigger Connector
✓	PixelPlant Connector
	CLIO Connector

Acquisition Features	
	Camera Pixel Clock Support
	85 MHz
✓	Area Scan Cameras
▶	8k * 4k max. image size
✓	Line Scan Cameras
▶	16k max. image width
✓	Grayscale Cameras
▶	8bit resolution
▶	16bit resolution
✓	Color Cameras
▶	24bit resolution (RGB)
▶	48bit resolution (RGB)
▶	24bit resolution (Bayer CFA)
▶	36bit resolution (Bayer CFA)
✓	Mixed Mode (requires VisualApplets)
▶	Area Scan + Line Scan Cameras
▶	Grayscale + Color Cameras
▶	Arbitrary Combinations

AddOn Products	
✓	GPIO Boards
✓	GPIO Boards, opto-isolated
	CLIO (Camera Link Replicator)
✓	PixelPlant (Processing Extension)

Physical Board Properties	
▶	168 mm length x 111 mm height
▶	Operating temperature 0°C - 40°C

Any information without obligation. Technical specifications and scope of delivery are liability-free and valid until revocation. Mistakes are excepted.



Image Acquisition Features

- Synchronous Acquisition Process
- Multi-Camera Acquisition Ability
- Knee Lookup Table
- Basic Image Processing, e. g. Brightness, Contrast and Gamma Correction
- Real-Time Bayer Conversion
- Internal 16bit Processing
- Regions of Interest (ROI)
- Hardware Generated Image Number
- Reads Gen<i></i>Cam Configuration
- Highly Customizable I/O System
- Dig I/O Signals

... and further ones

Special Features

- Support of Jumbo Packets (*future feat.*)
- Automatic Image Reconstruction from Data Packets
- Reduction of Interrupt Load to 1 IRQ/img
- 0% CPU Load

... and further ones

Software Products

- ✓ Device Drivers
- ✓ Firmware Flasher
- ✓ microDisplay
- ✓ microDiagnostics
- ✓ GigE Explorer
- ✓ microEnable SDK

Processing Libraries

incl.	AcquisitionApplets
incl.	SmartApplets Base
opt.	SmartApplets Extended
incl.	VisualApplets Base
opt.	VisualApplets Blob
opt.	VisualApplets Compression

Processing Licenses (Base version)

- ✓ SmartApplets enabled
- ✓ VisualApplets enabled

Operation Systems

✓ Windows XP	32bit	64bit
✓ Windows Vista	32bit	64bit
✓ Windows 7	32bit	64bit
✓ Linux (Kernel 2.6.23+)	32bit	64bit

Hardware/Software Compatibility

- ✓ microEnable IV GigE x4 (*discontinued*)

Required Accessory

Power Supply (48V), internal, 30W

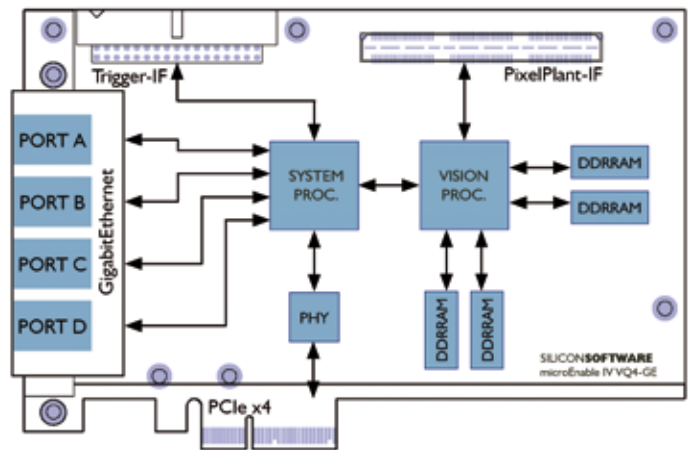

Schematic layout of microEnable IV VQ4-GE

Supported Features Sorted by Hardware Applets for

microEnable IV VQ4-GE

		Quad Area Bayer 24	Quad Area Gray 8	Quad Area Gray 16	Quad Area RGB 24	Quad Line Gray 8	Quad Line Gray 16	Quad Line RGB 24
Camera Support	GigE Vision	■	■	■	■	■	■	■
	Gen<i></i>Cam	■	■	■	■	■	■	■
Camera Type	Area Scan / Line Scan	A	A	A	A	L	L	L
	GrayScale / RGB / Bayer	BAY	G	G	RGB	G	G	RGB
	Supported Cameras	4	4	4	4	4	4	4
Color Processing	White Balancing	■						
	Bayer Bilinear Algorithm	■						
	Look-up Table		■					
Image Enhancement	Image Enhancements		■					
	Median Filter		■					■
	Image Processing		■					■
Image Correction	Image Format Reconstruction	■	■	■	■	■	■	■
	Signal Control	■	■	■				
Performances	Digital input signals	2	2	2				
	Digital output signals	2	2	2				
	I/O boards opto/TTL available	■	■	■	■	■	■	■
Image Formats	Max. width [in k pixels]	4	8	8	8	16	16	16
	Max. height [in k lines]	8	4	4	4	16	16	16
	Gray8 (8bit output)		■			■		
	RGB 24 (3x8bit output)	■			■			■

Any information without obligation. Technical specifications and scope of delivery are liability-free and valid until revocation. Mistakes are excepted.

